

## SPECIFICATIONS

MULTIFAMILY

### HOUSING

- Durable steel mounting frame
- Brushed nickel, white, or oil rubbed bronze finishes available

### ELECTRICAL

- 120V

### ILLUMINATION

- Frosted white glass shade
- 9W
- 630 lumens
- 50,000 hours @L<sub>70</sub>
- CRI: 80
- 3000K
- Dimmable TRIAC or ELV (10-100%)

### MOUNTING

- Wall mount

### CODE COMPLIANCE

- cETLus listed for damp locations
- Energy star listed

### WARRANTY

- 5 Year



**WSC26**  
Wall Sconce

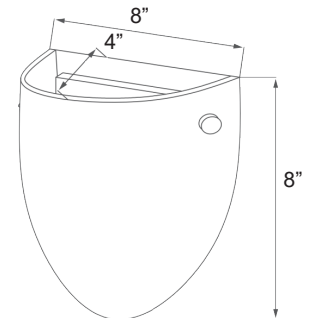

## ORDERING INFORMATION

CATALOG #	DESCRIPTION
WSC26-9L-120V-30K-*	9W, 630 lumens, 120V, 3000K
*Specify finish: <b>ORB</b> -Oil Rubbed Bronze, <b>WH</b> -White, <b>BN</b> - Brushed Nickel	